

Automatic Stretch Wrapper

Our ARPAC Brand EWA Model is a Rotary Tower style pallet wrapper with automatic functions for attaching, cutting, and securing the film to the load. Like all of our pallet wrappers, the EWA is constructed of heavy-duty, welded steel structures designed for long life and machine stability. Complete with easy to use Allen-Bradley controls, the EWA is an ideal solution for many applications.

A key benefit of this design is that no air is required, which makes this ideal for cold storage areas where air lines would freeze. It also offers a range of options for a variety of applications and load types, including cold and freezer packages, auto-roping, and tower and arm extensions for larger load types.



APPLICATIONS

- Automotive
- Beverage
- Building Supplies
- Consumer Goods
- Contract Packaging
- Food
- Health & Beauty
- Material Handling
- Printing & Publishing

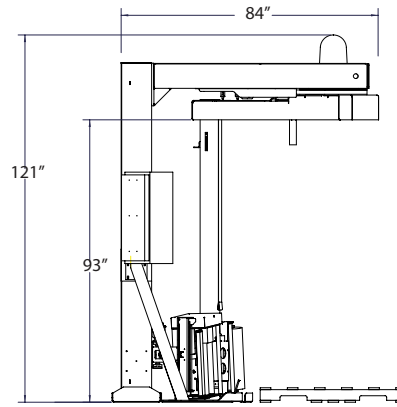
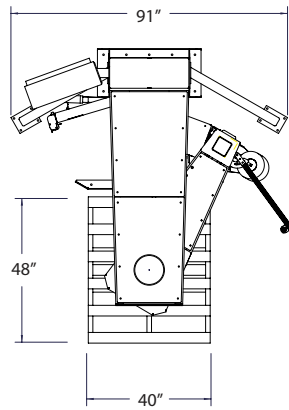

Final layout may vary.

FEATURES

- Heavy-duty, welded steel construction (no plastic panels) designed for long life
- Magnetic proximity switches in place of mechanical limit switches
- Long-range photo eye for automatic load height sensing
- Positive home position alignment
- Adjustable top and bottom illuminated LED wrap counter
- Allen-Bradley® power, control, and safety components
- Allen-Bradley® MicroLogix™ PLC
- User-friendly push-button operator control panel
- Built-in self-diagnostics
- EZ-Load® film pre-stretch dispenser for 20" film rolls
- Dual anti-static film rollers with manufacturer's lifetime warranty
- Electric clamp, cut and wipe-down system
- Top film overwrap control feature (TOC)
- Electronic film tension adjustment control on control panel
- Belt lift for quiet operation
- Dual V-belt drive rotating arm
- Dancer bar variable corner compensation
- Cycle pause feature and wrap arm control
- Manual jog control for rotating arm
- Flashing safety beacon
- Heavy-duty slewing bearing and NEMA 3 commutator
- NEMA 12 electrical cabinet
- UL/CSA approved components

OPTIONS

- Tower and arm extensions for wrapping loads up to load size: 60" L x 60" W x 110" H
- 30" film delivery system
- Automatic roping device
- Extended umbilical cord options
- Cycle counter
- Adjustable roping guide
- Automatic electrical roping
- Bottom rollover bar
- Remote start
- Pedestal mounted control cabinet
- Cold and freezer packages available
- Other NEMA rated control enclosures available

SPECIFICATIONS

- Speed: up to 15 RPM rotating table can deliver 25 - 55 loads per hour
- Variable carriage speed: up to 21 FPM
- Electrical power requirements: 120 VAC, 1 Ph, 60 Hz, 15 A (no options)
- Recommend dedicated 25 A circuit
- Compressed air requirements: none
- Max load: 53" W x 53" L standard
- Load height range: 24" H min, 80" H Standard,
- Film roll diameter: 20" standard
- Film pre-stretch capability from 150% to 300% stretch factor (200% standard)
- Machine dimensions: 84" L x 91" W (wrapper only) x 123" H (standard tower)
- Electrical: 120 V, 1 Ph, 60 Hz, 20 A, 2.4 kW