

Semi-Automatic Stretch

Our ARPAC Brand EW Model is a Semi-Automatic Rotary Tower style pallet wrapper. Like all of our pallet wrappers, the EW is constructed of heavy-duty, welded steel structures designed for long life and machine stability. Complete with easy to use Allen-Bradley controls, the EW is an ideal solution for many applications.

As a semi-automatic pallet wrapper, an operator manually attaches the film to the load and starts the stretch wrapping cycle. As soon as the wrapping sequence is completed, the film is manually cut and wiped onto the load to secure the film tail. A key benefit of this design is that no air is required, which makes this ideal for cold storage areas where air lines would freeze. It also offers a range of options for a variety of applications and load types, including cold and freezer packages, automatic film tear device, and tower and arm extensions for larger load types.



APPLICATIONS

- Automotive
- Beverage
- Building Supplies
- Consumer Goods
- Contract Packaging
- Food
- Health & Beauty
- Material Handling
- Printing & Publishing

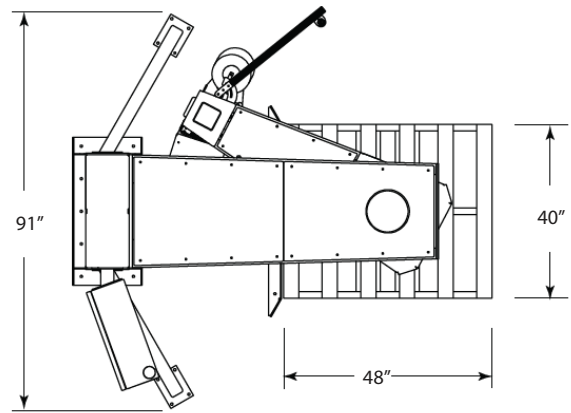
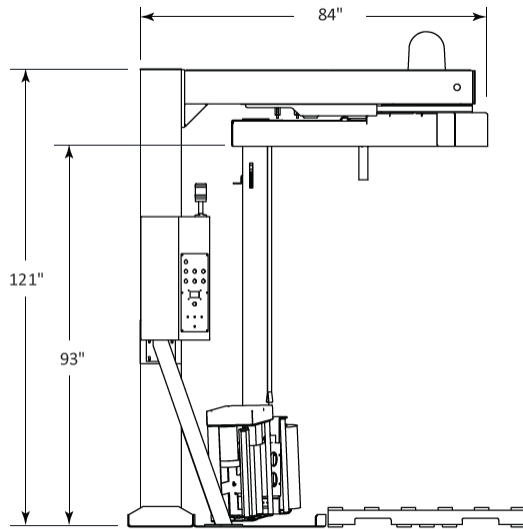

Final layout may vary.

FEATURES

- Heavy-duty, welded steel construction (no plastic panels) designed for long life
- Magnetic proximity switches in place of mechanical limit switches
- Long range photo eye for automatic load height sensing
- Positive home position alignment
- Adjustable top and bottom illuminated LED wrap counters
- Allen-Bradley® power, control, and safety components
- Allen-Bradley® MicroLogix™ PLC
- User-friendly push button operator control panel
- Built-in self-diagnostics
- EZ-Load® film pre-stretch dispenser for 20" film rolls
- Dual anti-static film rollers with manufacturer's lifetime warranty
- Top film overwrap control feature (TOC)
- Electronic film tension adjustment control on control panel
- Belt lift for quiet operation
- Dual V-belt drive rotating arm
- Dancer bar variable corner compensation
- Cycle pause feature
- Manual jog control for rotating arm
- Auto reset at end of cycle
- Manual wrapping cycle reset override
- Flashing safety beacon
- Heavy-duty slewing bearing and NEMA 3 commutator
- NEMA 12 electrical cabinet
- UL/CSA approved components

OPTIONS

- Tower and arm extensions
- 30" film delivery system
- Automatic film tear device
- Extended umbilical cord options
- Cycle counter
- Adjustable roping guide
- Automatic electrical roping
- Bottom rollover Bar
- Remote start
- Pedestal mounted control cabinet
- Cold and freezer packages available
- Other NEMA rated control enclosures available

SPECIFICATIONS

- Speed up to 15 RPM rotating arm can deliver 55 loads per hour
- Variable carriage speed up to 21 FPM
- Electrical Power Requirements: 120 VAC, 1 Ph, 60 Hz, 15 A
- Recommend dedicated 25 A circuit
- Compressed Air Requirements: None
- Max Load: 53" W x 53" L Standard, up to 60" W x 60" L Optional
- Load Height: 24" H min, 80" H Standard, up to 110" H Optional
- Film Roll Diameter: 20" Standard, up to 30" Optional
- Film pre-stretch capability from 150% to 300% stretch factor (200% standard)