

NVENIA
A DURAVANT COMPANY

**HAMER BRAND RPM-I
ICE ROBOTIC PALLETIZING SYSTEM**

The HAMER Brand Robotic Palletizing Module - Ice (RPM-I)

The HAMER Brand semi and fully automatic ice palletizers are designed to withstand harsh operating conditions and are configured using durable industrial components. Smart, yet simple to run with low operating and maintenance costs.

The HAMER Brand robotic ice palletizers are completely assembled, wired and tested in our state-of-the-art manufacturing facility. All systems are wired with conduit and j-boxes to make installation and re-assembly in your facility fast and easy. All palletizers are programmed and tested on the specific products they will be running to ensure stack quality, speeds, and any other required specifications.



AUTOMATIC SINGLE OR DUAL STACK SYSTEMS

- Small footprint
- Low cost, high productivity
- Single or dual cell configurations

Hamer Brand semi-automatic ice palletizers are an efficient palletizing solution, providing 80% of palletizing automation at a significantly lower cost than fully automatic systems. Safety light curtains and controls ensure the robot is not active in a stacking cell when fork trucks are present. Semi-automatic palletizers can be configured in dual stacking cell (shown) or single stacking cell configuration.

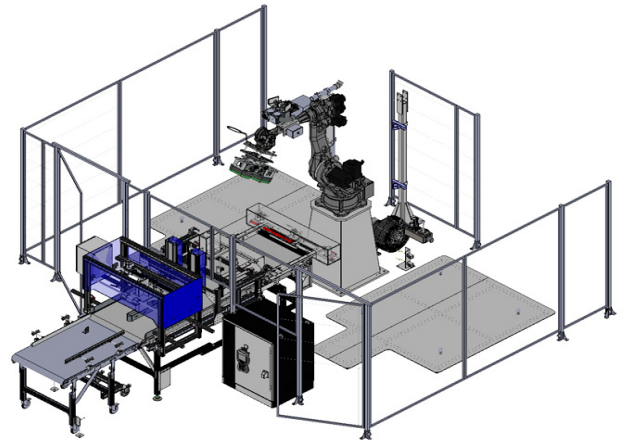

Dual Stacks, Semi-auto Palletizing

FULLY AUTOMATIC PALLETIZING SYSTEMS

- Automate from bagging line to stretch wrapper
- 100% of palletizing labor is eliminated
- Highest production rates

To maximize impact of automated palletizing, the addition of a Pallet Dispenser, Slip Sheet Dispenser and fully automatic Full Pallet Transfer Conveyors provide a completely automated palletizing system. This system feeds empty pallets with or without slip-sheets automatically to the Stacking area. Products are then picked and stacked on the pallet. When complete, the full pallet is transferred to in-line stretch wrapping or stretch hooding equipment.

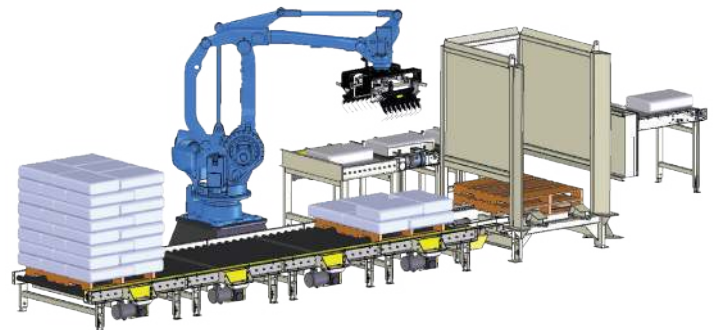

Fully Automatic Palletizing



Pallet Dispenser



Slip Sheet Dispenser

EXCLUSIVE EasyPic™ OPERATOR HMI

The EasyPic HMI allows for fast and easy adjustment the pallet stack, uploading stored pallet configurations or creating new pallet designs.



END-OF-ARM TOOLING – (EOAT)

We offer a wide variety of End of Arm Tools to meet any palletizer application. All Hamer Brand EOAT solutions are solidly built, easy to maintain and deliver maximum performance. Single pick, multi-pick, gripper or vacuum are proven performers.



INDUSTRIAL, HEAVY DUTY CONVEYORS

Our palletizing system conveyors are designed to withstand the harshest ice production environments. Our infeed conveyors are A/C driven plastic modular chain, aluminum and stainless steel frame construction. Our CDLR, chain driven live roller, full pallet conveyors come in 3,000lb or 5,000lb and are built using 6" structural steel channel with powder coat finish.

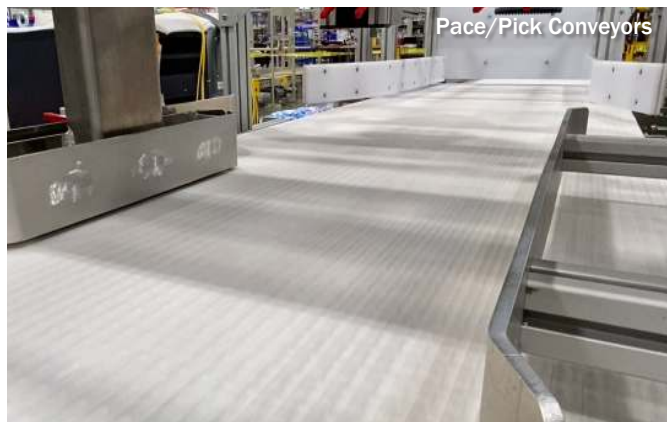

FEATURES

- Fastest palletizing rates
- Bag, case, pail/bucket palletizing
- Small footprint systems
- Programmable/selectable pallet patterns
- Yaskawa/Motoman/Fanuc industrial robotic arm
- Allen-Bradley® PLC with Touchscreen
- 80, 100, 190kg capacity robot arm
- Robot mounting base
- Robot teach pendant
- Industry standard wire mesh safety guarding with interlock access door
- Safety compliant to ANSI/RIA Safety requirements

SPECIFICATIONS

- Single pick; up to 13 bags/minute
- Multiple picks; up to 50+ bags per minute
- Power: 460V, 3 Ph, 60 Hz
- Air: 2-15 CFM @ 80 PSI (design dependent)
- Controls: NEMA 12 enclosure, UL/cUL
- Safety: Design/Controls are compliant to ANSI/RIA requirements

OPTIONS

- EasyPic™ Operator HMI
- Fully automatic or semi-automatic systems
- Multiple robot arm models
- NEMA 4X controls and robot protection packages
- Access to full line of Yaskawa/Motoman robots for custom solutions
- Corrosion resistant packages for conveyors
- Various power options
- End-of-arm tooling:
 - Bag Clamp, single or multiple pick
 - Bag Clamp, fixed size, manually or servo/automatically adjustable
 - Vacuum, single or multiple pick
- Multi-function end-of-arm tooling:
 - Slip-sheet pick/place
 - Auto height sensor
- Multiple pick points
- Multiple stack points
- Custom conveying for ice bag, conditioning, in-feed, pacing, picking, power curves, accumulating
- Automatic Pallet Dispenser
- Automatic Slip Sheet Dispenser
- CDLR full pallet conveyors
- 90 degree full pallet transfer
- Quad muting light curtains for continuous operation (semi auto.)
- Integrated automatic stretch wrapper or stretch hooder

ABOUT MODERN ICE

Modern Ice Equipment and Supply has been a part of the ice industry since 1968. They have grown to become a full-service supplier offering not only parts and supplies, but also equipment, equipment training, technical service and consultation, installation, manufacturing, marketing aids, professional sales training, layout and design services, turn-key engineering solutions, and the knowledge and experience that adds value to the equipment, parts, and suppliers.

Modern Ice's commitment to serving the ice industry is founded on strong partnerships and longstanding relationships that begin with their OEMs, extend through their dealers and ultimately deliver profitable results for their customers.

CONTACT MODERN ICE @ 1.800.543.1581



Call Us:
1.800.543.1581 or 1.513.367.2101
Email Us:
nVeniaequipment@modernice.com
nVeniaparts@modernice.com
www.modernice.com



750 N. Wood Dale Road
Wood Dale, IL 60191
www.nVenia.com