



NVENIA
A DURAVANT COMPANY

**PRE-MADE POUCH
ROTARY BAGGING MACHINE**

Pre-Made Pouch Rotary Bagging Machine

Model ROFS-1012-SS-H-Z

The new Ohlson Rotary Pouch Bagging Machine has been completely redesigned yielding a more robust and faster machine in order to maximize production output for product being filled in a pre-made bag and stand-up pouches.

FEATURES

- Stainless Steel Construction
- Centralized Adjustments For Gripper Width
- User Friendly Color Touch Pad
- Bag Magazine
- Bag Opening Blade With Full Opening Detector
- Bag Deflator
- Discharge Conveyor
- Auto-bag sizing option

Note: All features may not be available for all models



COMMON ACCESSORIES

- Dust collector unit
- Date code printer (Bag samples and desired printing locations must be approved)
- Product Settler
- Gas injection
- Zipper opener assist option
- Product deflator chute
- Locking casters
- Timing gate to improve speed
- Liquid pump/valve for liquids and oils (to be deposited into bag)

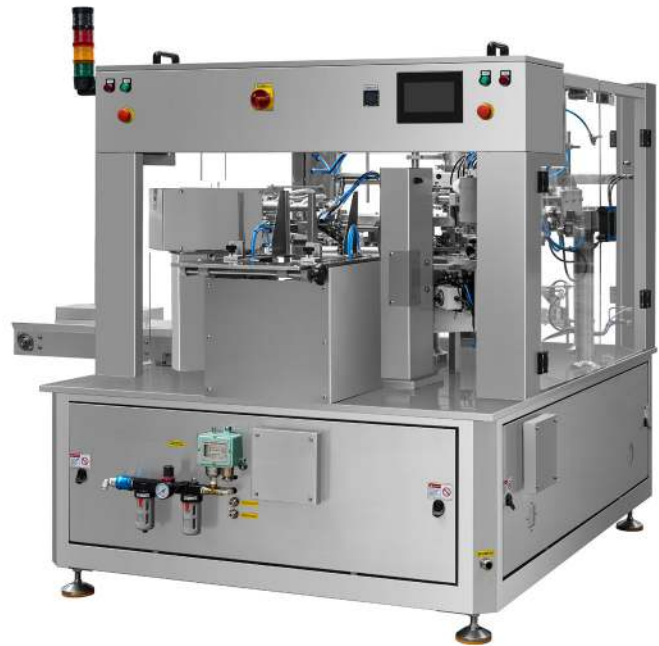

INDUSTRIES



Bakery/
Confection



Snacks



Bulk Food



Fruits/
Veggies



Meat/Poultry/
Fish



Pet
Food



Pharma-
ceuticals



Health &
Beauty

Product Dimensions

ROFS-1012-SS-H-Z

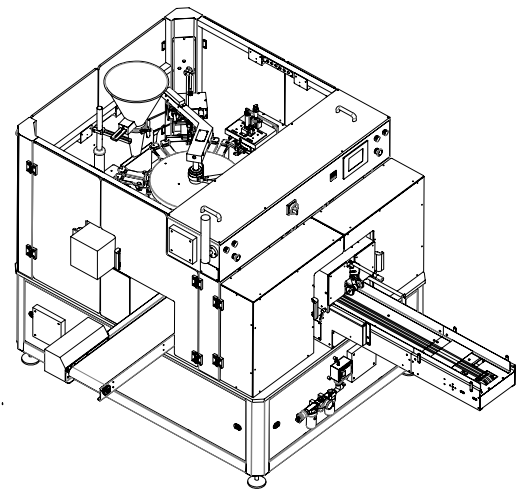
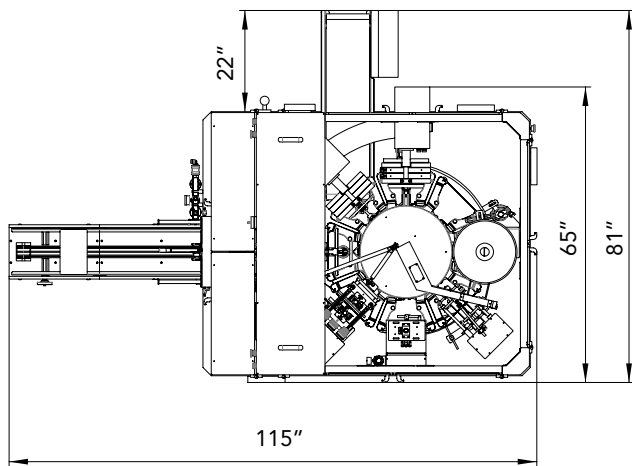
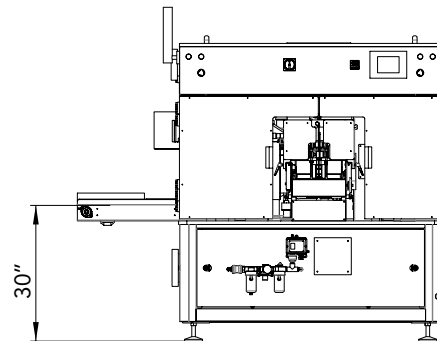
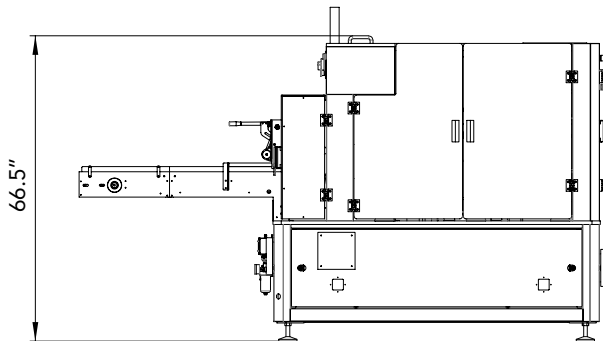

KEY SPECIFICATIONS

Specs may vary based on specific options and/or additional system requirements

	ROFS-1012-SS-H-Z
Pouch Width	4.3" To 9.8"
Pouch Length	5.9" To 13.7"
Max Weight	5 lbs.
Max Speed*	Up to 75 Pouches/Minute
Power Req.	15A 220VAC Three Phase @ 60HZ
Air Req.	18CFM @ 85PSI
Dimensions	114.8"x80.9"x66.4"

*Final quoted speeds are product and weight-dependent



NVENIA

750 N. Wood Dale Road
Wood Dale, IL 60191
info@nVenia.com
800.253.5103
www.nVenia.com

SUPPORTPRO

3500 Lacey Road, Suite 290
Downers Grove, IL 60515
support@supportpro.pro
844.777.8776
www.supportpro.pro