

Hot Air Sealer

The Fischbein Model HAS 300 Hot Air Sealer is a high-production sealing system that efficiently closes a wide range of heat sealable pillow-type and gusseted bags at up to 60 linear feet per minute. Easily adjustable controls for the heaters, air flow, and carry through belts ensure consistent, sift proof sealing for a variety of bag sizes and thicknesses. There are NO BANDS required to seal gusseted bags, eliminating related maintenance cost and downtime.



APPLICATIONS

- Bakery Mixes
- Fertilizers
- Powdered Dairy Products
- Minerals
- Agricultural Seed
- Pet Food
- Chemicals
- Feed Additives
- Cat Litter

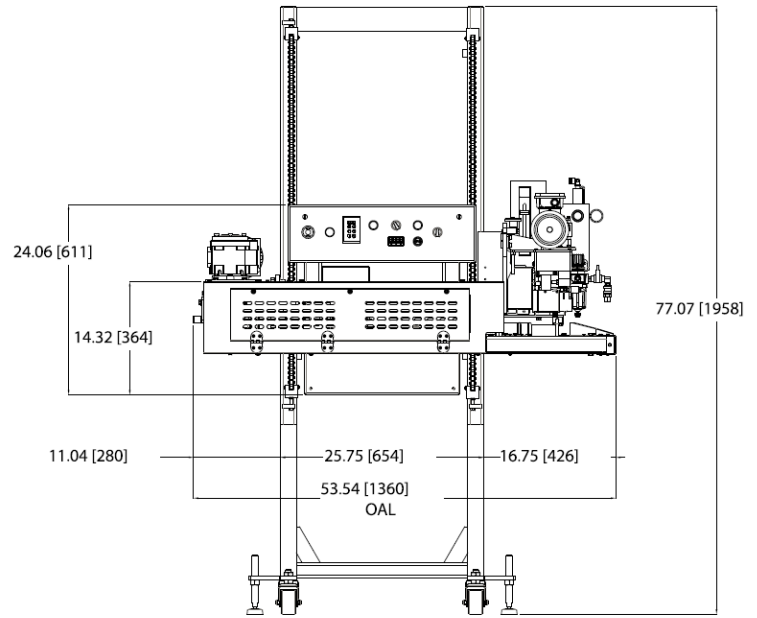
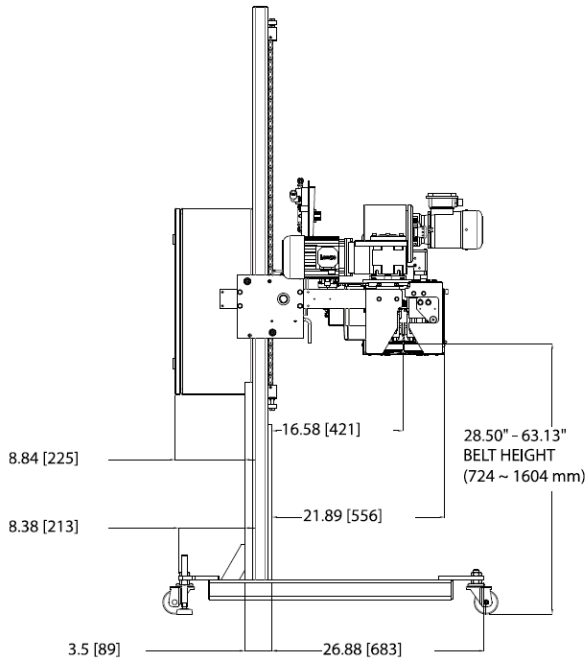

HAS300

FEATURES

- **Bag Types:** Seals pillow and gusseted style polyethylene bags without the use of bands.
- **Consistent, Continuous Production:** Dual VFDs provide synchronous compression wheel and carry through belt speed control. The result - strong, sift-proof closures, every time.
- **No Bands:** Eliminate maintenance costs and downtime - no bands required to seal gusseted bags.
- **User Friendly Controls:** Safe and easy to use control panel with digital temperature display, key pad for variable speed control, and dual emergency stop buttons.

OPTIONS

- Left to right operation
- Motor starter and contactor for conveyor
- Air wash system with high performance bag top trimmer
- CR Plus 2 part corrosion resistant powder coat finish
- Stainless Steel NEMA 4 washdown model

SPECIFICATIONS

- Dimensions: 123in(312.4 cm), D 37 in (94 cm), H 72in(183 cm)
- Speed: Up to 75 linear feet per minute
- Electric(NEMA 12): 230/330/460V-3PH-60Hz, 24 VAC
- Air: 10cfm @ 80-100 PSI

BAGS

- Bags Types: Multi-wall paper gusseted open mouth pinch bags with heat sealable inner liner.
- Gussets: Any size including flat bags
- Free Bag Top: Minimum 6 in(15.2 cm)