

### Extreme Series High Speed Shrink Tunnel

Our ARPAC Brand XT tunnels employ a unique chamber design and airflow system that allow the operator complete control of the shrink process, whether the product and film require a gentle air flow or greater circulation for high speeds and high quality shrink.

The XT shrink tunnel range offers an innovative bottom pre-shrink design that gives tight control of seal placement. On thin products the seal can be placed on the edge or bottom of the package. The directional air flow controls eliminate dog ears and small wrinkles providing a pristine and aesthetic end package.

Compared to other tunnel designs that use dual chambers, this single chamber design is shorter, saving valuable factory space. Single chamber designs require fewer components and controls, lowering repair and maintenance costs while increasing longevity and reliability of the tunnel.



#### APPLICATIONS

- Automotive
- Beverage
- Building Supplies
- Consumer Goods
- Contract Packaging
- Food
- Health & Beauty
- Material Handling
- Printing & Publishing

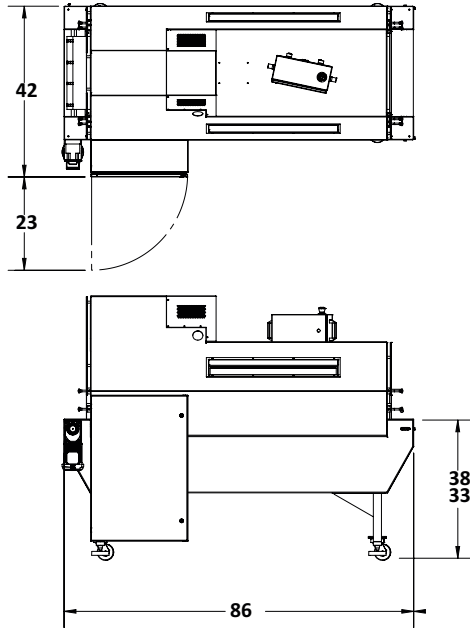

Final layout may vary

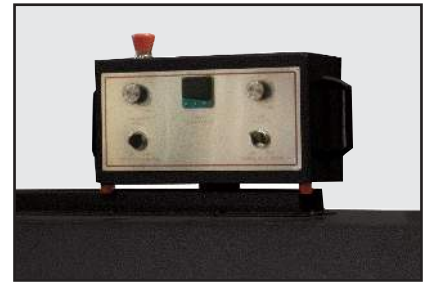

Easy To Use Swivel Control Panel



Chain Mesh Belt & Viewing Windows on Both Sides

## FEATURES

- Heavy duty welded construction
- Powder coat finish provides a durable scratch resistant surface that prevents corrosion
- Bottom pre-shrink section in chamber controls seal placement on the package
- Heavy duty wire belt is a zero maintenance item
- Universal swivel operator station for access from either side
- Digital temperature control maintains precise internal temperatures
- AC variable frequency drive blower motor offers precise air flow control
- Directional air flow dampers (8 zones) allow for tight product tuning
- Product viewing windows on both sides of tunnel provide a clear view of the shrink process
- Easy access to all components simplifies maintenance and repair

## SPECIFICATIONS

- Speed: up to 180 feet per minute
- Electrical power requirements: 240/480 VAC, 3 Ph, 60 Hz
- XT18 chamber size: 21.5" W, 72" L, 12.5" H
- XT18-EXT chamber size: 21.5" W, 96" L, 12.5" H
- XT30 chamber size: 33" W, 72" L, 16" H

## OPTIONS

- Tunnel controls integrated into wrapper PLC
- Standard or customized belt designs
- Internal tunnel guides to protect against product fall-down and jams