

## Intermittent Motion Wraparound Case Packer

Our ARPAC Brand PC-2000 Model is a high performance, intermittent motion wraparound case and tray packer.

The system is capable of running up to 20 cases or trays per minute. This model uses up to 20% less corrugated material as compared to top load regular slotted cases (RSC's) resulting in significant annual material savings. This rugged machine reduces labor, increases productivity, reduces packaging costs and integrates easily into new or existing packaging lines.

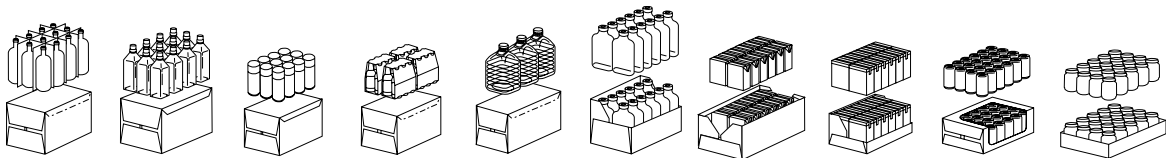

### APPLICATIONS

- Automotive
- Beverage
- Building Supplies
- Consumer Goods
- Contract Packaging
- Food
- Health & Beauty
- Material Handling
- Printing & Publishing

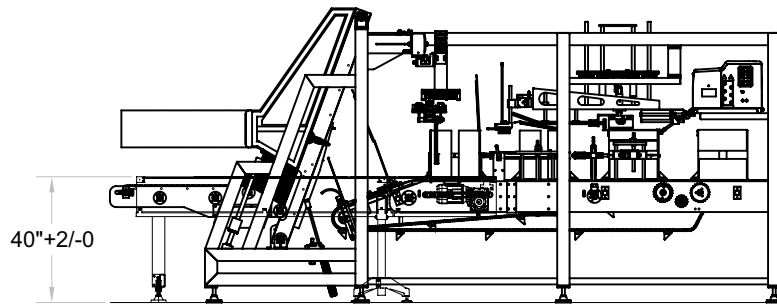
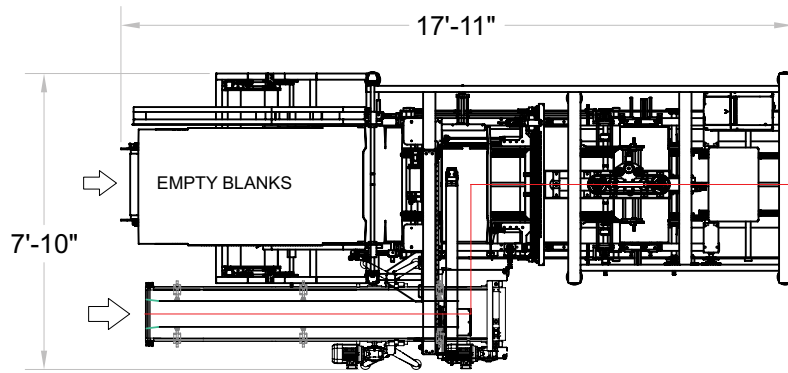

Final layout may vary.



Loading Section



Standard Blank Magazine Hopper



User-Friendly Control Panel

## FEATURES

- Rugged chain drive construction for maximum durability
- Smooth infeed pneumatic clamp and push collation provides easy product control
- Topped product sensors alert operator protecting against product jams
- Case or tray forming lugged conveyor for versatile operations
- Nordson ProBlue series hot melt adhesive system
- Positive engagement compression sections provide additional pressure for flap folding

## OPTIONS

- Dedicated glue nozzles for quicker product changeover
- Additional blank feed capacity magazine
- Servo driven product collation

## SPECIFICATIONS

- Speed up to 20 packages per minute
- Electrical power requirements: 240 V or 480 VAC, 3 Ph, 60 Hz
- Compressed air requirements: 20 SCFM @ 80 psi

## PRODUCT DIMENSIONS

- Minimum product size: 7" W, 3.2" L, 4.7" H
- Maximum product size: 23.2" W, 15.3" L, 14.7" H

## CORRUGATE

- B flute Kraft corrugation
- Burst strength: 150 or 200 lb per square inch
- Balanced outside and inside liners to avert warped blanks
- Minimum combined weight facings: 98 lb per square inch